

# FM12AD-V

## 12.1" Windows Warehouse Computer with Intel® Alder Lake Processor



### KEY FEATURES

- 12th Gen. Intel® Processor Family – Alder Lake Processor
- 12.1" 1024 x 768 Panel with PCAP touch screen warehouse computer
- IP65 waterproof and dustproof
- Wide power input 10-60V DC with ignition
- Wide range operating temperature
- Support VESA Mount



### SPECIFICATIONS

Display			
Type	Projected Capacitive Multi Touch	Touch Mode	Support Hand, Stylus, Glove Mode
Resolution	1024x768	Size	12.1 inches
Contrast Ratio	1000:1	Panel Brightness	400 nits 800 nits(Optional)
View Angles	89,89,89,89		
System Specification			
Processor	Intel® Core™ i5-1235U 3.30 GHz (up to 4.40 GHz)	Memory	8GB DDR5 SDRAM, up to 32GB
Storage	128GB NVMe SSD 256GB NVMe SSD (Optional)	Security	TPM 2.0
Operating System	Windows 10 IoT Enterprise	WLAN	Support
BT	Support	WWAN	LTE/5G Sub 6 (Optional)
GNSS	GPS/GLONASS (Optional)	Sensors	G-Sensor, Light Sensor ,Temp Sensor
Camera			
Front Camera	2MP Camera		
Mechanical			
Dimension	307 x 225 x 57 mm	Weight	2.5 kg
Mounting	RAM Mount/ VESA Mount	Cooling System	Fanless Design
IO Ports			
USB Port	1 x USB 3.0 Type C (OTG) 1 x USB 2.0 Port	Serial Port	2 x RS232/422/485 (Default RS232)
SD Card Slot	1 x Micro SD Card Slot	SIM Card Slot	1 x Dual-Nano SIM Card Slot
Audio	1 x Audio(Mic in & Line Out) either one with DIDO (Optional)	LAN	1 x Gigabit LAN port PSE (IEEE 802.3at 30W) (Optional)
Indicator	4 x LED Indicator	DIDO	1 x DIDO (2XDI ; 2XDO) either one with Audio (Optional)
CANBUS	1 x CANBus (Optional)		
Environment			
Operating Humidity	5% to 95% RH, Non-Condensing	Operating Temperature	-30°C to 50°C
Storage Temperature	-30°C to 60°C	Shock	MIL-STD-810H Method 516.8 Procedure I

<b>Vibration</b>	MIL-STD-810H Method 514.8 Procedure I	<b>IP rating</b>	
<b>Impact</b>	Support EN62262 IK07 Rating	<b>ESD</b>	
<b>Certification</b>			
<b>Certification</b>	CE, FCC FCC (Electromagnetic Emissions), IC (ICES-003) UL60950-1, EN60950-1, PTCRB		
<b>Control</b>			
<b>Button</b>	1 x Power Button, 5 x Function Button (Programmable Function Key Configured by Winset)		
<b>Power</b>			
<b>Battery</b>	2400mAh UPS Battery for 1 hour backup (Optional)	<b>Power Rating</b>	10V~60V with ignition control
<b>Security Function</b>			
<b>SOTI MobiControl</b>	SOTI MobiControl Compliance		
<b>Accessory</b>			

**Accessory**

- 5M Power Cable with Fuse Kit
- 0.15M Power Converter Cable
- DC Jack Power Cable
- 84W Adapter with power cable
- Quick Start Guide

**Optional Accessory**

- Stylus Kit + Screw
- 1.8M RS232 Cable
- 2M IP65 LAN Cable
- GPS & LTE 2M Combo Antenna(VM240)
- GPS & LTE 5M Combo Antenna (VM9C)
- GPS & LTE Magnetic Combo Antenna (VM10S)
- GPS Antenna
- WWAN Antenna
- 2M Waterproof USB Type-A to A Cable
- Cable Clamp Kit
- COM Port + CANBus Cable
- COM Port + DIDO Cable

## DIMENSIONS UNIT:MM

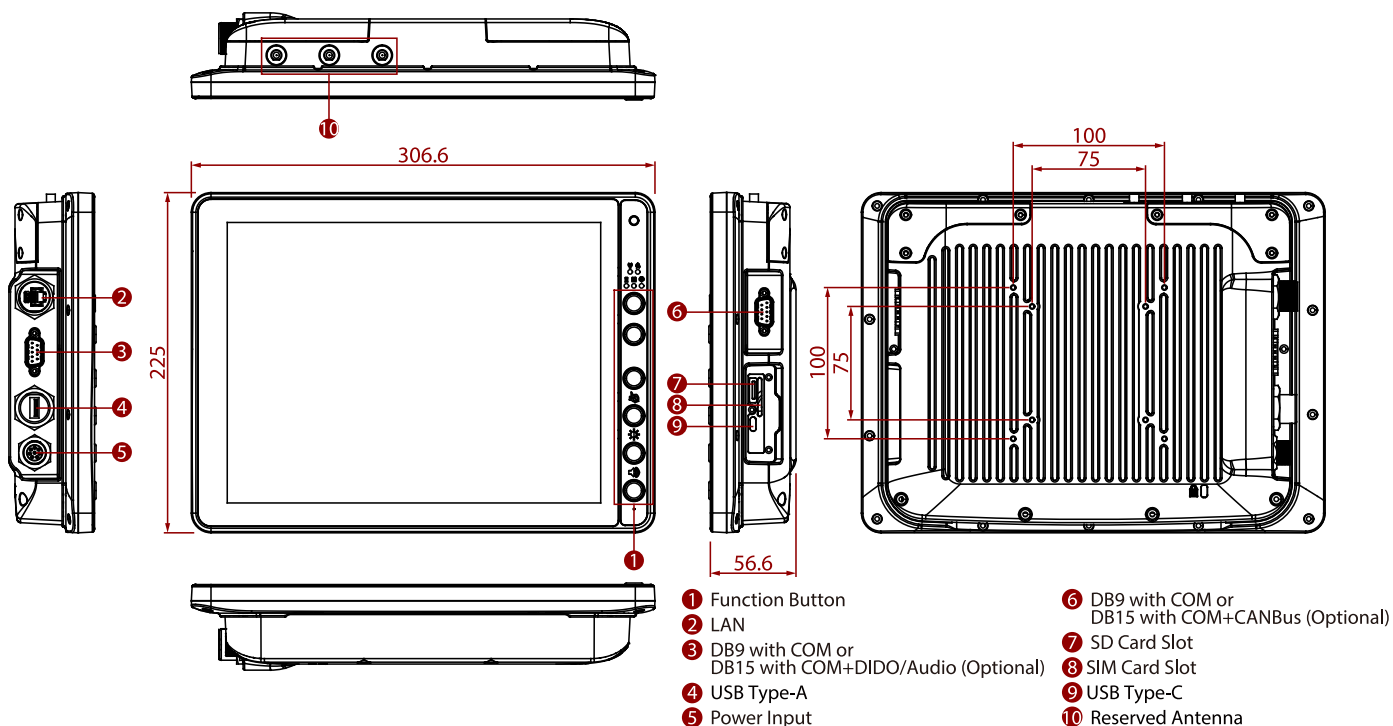

## NOTE

1. This is a simplified drawing and some components are not marked in detail.
2. Please contact our sales representative if you need further product information.
3. All specifications are subject to change without prior notice.
4. The product shown in this datasheet is a standard model. For diagrams that contain customized or optional I/O, please contact the Winmate Sales Team for more information.
5. COM port can supply 5V power via the 9th pin.