

FM12Q-V

12.1inch Android Vehicle Computer with Qualcomm Snapdragon™ 660

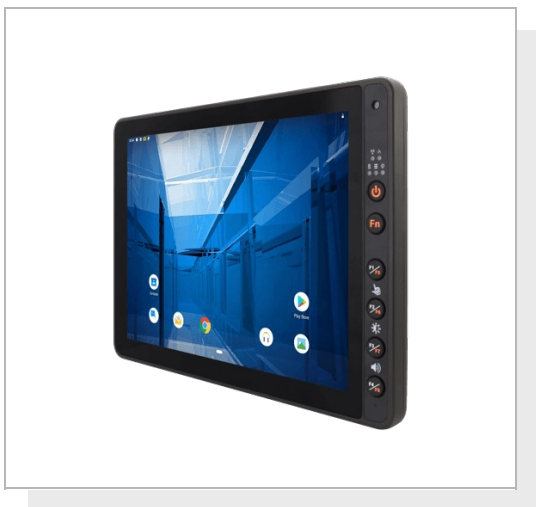

KEY FEATURES

- Qualcomm Snapdragon™ 660 octacore, 2.2 GHz CPU
- 12.1" 1024 x 768 Panel with PCAP Touch, Android vehicle computer
- IP65 waterproof and dustproof
- Wide power input 10-60V DC with ignition
- Wide range operating temperature
- Support VESA Mount



SPECIFICATIONS

Display			
Type	Projected Capacitive Multi Touch	Touch Mode	Support Hand, Stylus, Glove Mode
Resolution	1024x768	Size	12.1 inches
Contrast Ratio	1000:1	Panel Brightness	400 nits 800 nits(Optional)
View Angles	89,89,89,89		
System Specification			
Processor	Qualcomm® Snapdragon™ 660 (Octa-Core 2.2 GHz)	Memory	3GB
Storage	32GB	Operating System	Android 9.0
WLAN	Support	BT	Support
WWAN	4G/LTE (Optional)	GNSS	GPS/GLONASS (Optional)
Sensors	G-Sensor, Temp. Sensor		
Camera			
Front Camera	2MP Camera		
Mechanical			
Dimension	307 x 225 x 57 mm	Weight	2.5 kg
Mounting	RAM Mount/ VESA Mount	Cooling System	Fanless Design
IO Ports			
USB Port	1 x USB 3.0 Type C (OTG) 1 x USB 2.0 Port	Serial Port	2 x RS232/422/485 (Default RS232)
SD Card Slot	1 x Micro SD Card Slot	SIM Card Slot	1 x Dual-Nano SIM Card Slot
Audio	1 x Audio(Mic in & Line Out) either one with DIDO (Optional)	LAN	1 x Gigabit LAN port PSE (IEEE 802.3at 30W) (Optional)
Indicator	3 x LED Indicator (WLAN, UPS battery, Heater)	DIDO	1 x DIDO (2XDI ; 2XDO) either one with Audio (Optional)
CANBUS	1 x CANBus (Optional)		
Environment			
Operating Humidity	5% to 95% RH, Non-Condensing	Operating Temperature	-30°C to 50°C
Storage Temperature	-30°C to 60°C	Shock	MIL-STD-810H Method 516.8 Procedure I

Vibration	MIL-STD-810H Method 514.8 Procedure I	IP rating	IP65
Impact	Support EN62262 IK07 Rating	ESD	Compliant with EN 61000-4-2, Enhanced ESD to ±8kV Direct & ±15kV Air
Certification			
Certification	CE, FCC		
Control			
Button	1 x Power Button, 5 x Function Button (Programmable Function Key Configured by Winset)		
Power			
Battery	400mAh UPS Battery for 20 minutes backup (Optional)	Power Rating	10V~60V with ignition control
Security Function			
SOTI MobiControl	SOTI MobiControl Compliance		
Accessory			

Accessory

- 5M Power Cable with Fuse Kit
- 0.15M Power Converter Cable
- DC Jack Power Cable
- 84W Adapter with power cable
- Quick Start Guide

Optional Accessory

- Stylus Kit + Screw
- 1.8M RS232 Cable
- 2M IP65 LAN Cable
- GPS & LTE 2M Combo Antenna (VM240)
- GPS & LTE 5M Combo Antenna (VM9C)
- GPS & LTE Magnetic Combo Antenna (VM10S)
- GPS Antenna
- WWAN Antenna
- 2M Waterproof USB Type-A to A Cable
- Cable Clamp Kit
- COM Port + CANBus Cable
- COM Port + DIDO Cable

DIMENSIONS UNIT:MM

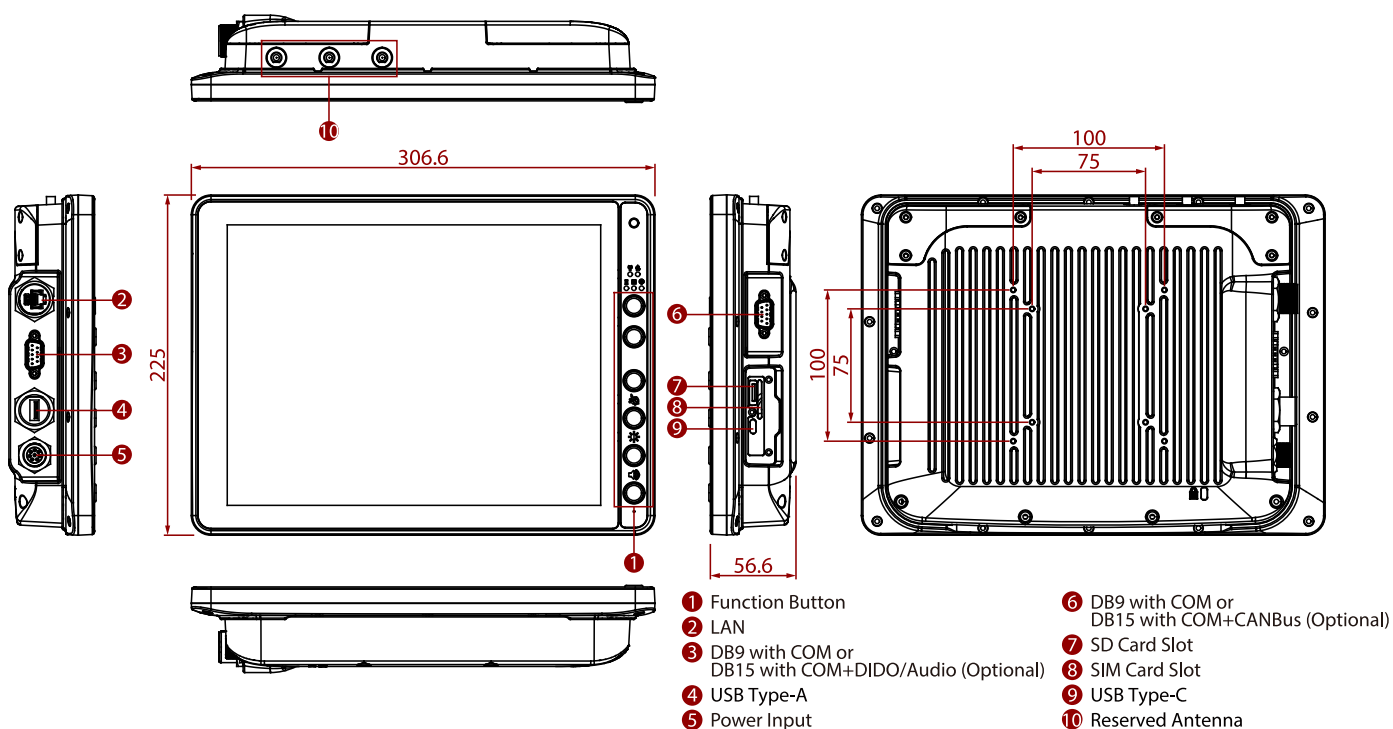

NOTE

1. Total usable memory will be less dependent upon actual system configuration.
2. SOTI is available upon request.
3. Length measurements do not include protrusions. Weight varies with options.
4. Measured at dimming LCD brightness. Varies depending on the usage conditions, or when an external device is attached.
5. Accessories may vary depending on your configuration.
6. This is a simplified drawing and some components are not marked in detail.
7. The product shown in this datasheet is a standard model. For diagrams that contain customized or optional I/O, please contact the Winmate Sales Team for more information.
8. The UPS battery is only expected to use for backup under low system loading and without I/O function.
9. COM port can supply 5V power via the 9th pin.