

R15IB3S-67C3(HB)

15" Intel® Celeron® N2930 G-WIN Full IP67 Panel PC



KEY FEATURES

- Intel® Celeron® Bay Trail N2930 1.83GHz Processor Fanless Design
- High Quality 15" Panel, 1024 x 768 resolution, 300 nits (Optional for 1000 nits)
- IP67 Dust/ Water proof design with VESA mount
- Aluminum Die-Casting Housing with Anti-Corrosion Treatments
- Build in ambient Light sensor
- Wide Range 9 to 36V DC Input with isolation
- Optional 6-60V DC Input, and Optional for Ignition On/Off delay
- 5 Wire Resistive Touch / Anti-Reflective Protection Glass (Optional)
- Optional HB/Sunlight Readable up to 1000 nits
- Design to meet EN50155, 15inch Full IP67 Panel PC



SPECIFICATIONS

System Specification			
Processor	Intel Celeron N2930 1.83GHz (up to 2.16GHz)	Memory	1 x SO-DIMM, DDR3L 1600 MHz, 4GB 8GB (Optional)
Storage	1 x mSATA SSD 128GB. mSATA SSD up to 512GB. (Optional)	Ethernet controller	2 x Intel® Ethernet Controller
Operating System	Windows 10 IoT Enterprise (64 bit) (Optional) Linux Ubuntu 20.04 (Optional)	WLAN	Support (Optional)
BT	Support (Optional)		
Display			
Resolution	1024x768	Size	15.0 inches
Contrast Ratio	2000:1	Panel Brightness	300.0 nits
View Angles	88,88,88,88	Active Area	304.1x228.1 mm
Touch / Glass	Resistive Touch Screen Bonding With Panel Protection Glass Without touch function (Optional)	Optional function	High brightness Panel for sunlight readable (Optional)
Mechanical			
Dimension	398 x 308 x 58 mm	Weight	4.2 kg
Mounting	VESA Mount Yoke Mount	Enclosure	Aluminum Housing
Cooling System	Fanless design		
Environment			
Operating Humidity	10% to 90% RH, Non-Condensing	Operating Temperature	-10°C to 55°C -40°C to 70°C (with intelligent heater)
Storage Temperature	-30°C to 70°C	Shock	MIL-STD-810G Method 516.6 Procedure I (Optional)
Vibration	MIL-STD-810G Method 514.6 Procedure I	IP rating	IP67
Certification			
Certification	CE, FCC		
IO Ports			

Power Input	1 x M12 waterproof connector for 9~36V DC	USB Port	1 x M12 waterproof connector for 2 x USB2.0
Serial Port	1 x M12 waterproof connector for RS232	LAN	1 x waterproof Giga LAN RJ45 connector
Indicator	1 x LED Indicator for power 1 x LED Indicator for storage		
Control			
Button	1 x Power Button 1 x Reset Button 1 x Lock / Unlock front key function button 1 x Auto Dimming / Manually button 1 x Day / Night Mode button 1 x Brightness Up button 1 x Brightness Down button 1 x LED indicator brightness adjustment button 1 x Light sensor		
Accessory			
Accessory	External open wire Power cable with waterproof connector External USB cable with waterproof connector External COM cable with waterproof connector External LAN cable with waterproof connector Waterproof caps RJ45 female-female converter VESA screws	Optional Accessory	Yoke mount stand (Optional) 100~240V AC to DC Adapter with power cord (Optional)

DIMENSIONS UNIT:MM

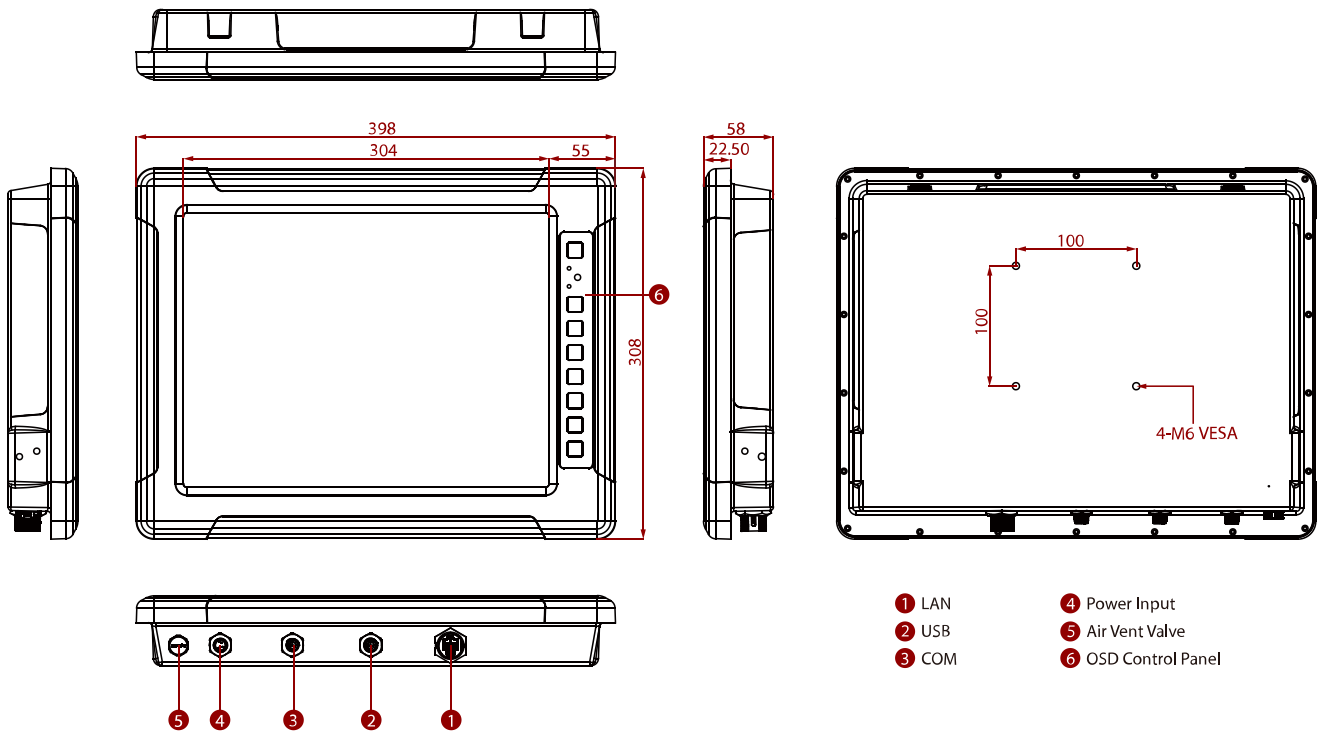

NOTE

1. This is a simplified drawing and some components are not marked in detail.
3. Weight of the device varies by configuration.
4. Please contact our sales representative if you need further product information.
5. All specifications are subject to change without prior notice.
6. The product shown in this datasheet is a standard model. For diagrams that contain customized or optional I/O, please contact the Winmate Sales Team for more information.