

R15IM3S-PTC3

15" ARM A53 PT Series HMI Panel PC

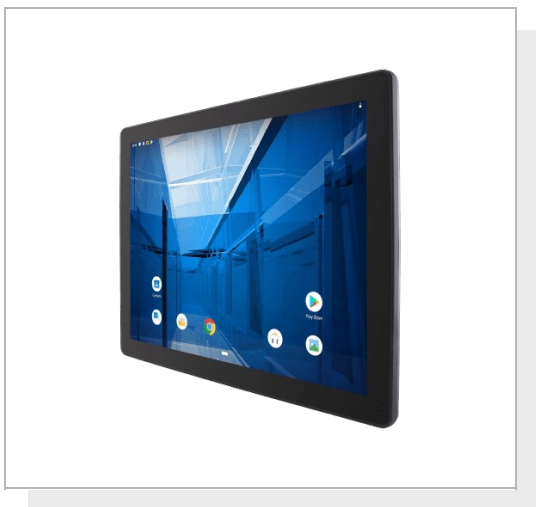

KEY FEATURES

- 15" 1024 x 768 with PCAP touchscreen
- ARM A53 Quad Core 2.0GHz
- Fanless cooling system and Ultralow power consumption
- Onboard 32GB eMMC
- Onboard LPDDR4 4GB
- Android 11 HMI Panel PC
- Front IP65
- Support Android or Linux operating system



SPECIFICATIONS

Display			
Resolution	1024x768	Size	15 inches
Contrast Ratio	800:1	Panel Brightness	350 nits
View Angles	80,80,70,80	Active Area	304.128x228.096 mm
Touch / Glass	Projected Capacitive Multi Touch Screen		
System Specification			
Processor	ARM A53 Quad Core 2.0GHz	Memory	4GB LPDDR4
Storage	32GB eMMC	Operating System	Android 11 (Upgradeable to Android 13) Linux Yocto 5.10.104 with QT 5.15 (Optional) Linux Ubuntu (in 2023) (Optional)
Environment			
Operating Humidity	10% to 90% (non-condensing)	Operating Temperature	0~50°C
Storage Temperature	-20~60°C	IP rating	Front IP65
Certification			
Certification	CE, FCC		
Mechanical			
Dimension	352.5 x 276.7 x 45.45 mm	Mounting	VESA Mount (100x100mm, 75x75mm)
Enclosure	Plastic	Cooling System	Fanless Design
IO Ports			
USB Port	2 x USB 2.0, 1 x USB OTG	Serial Port	1 x RS-232/422/485
SD Card Slot	1 x Micro SD Card Slot (Max to 32GB)	Audio	2 x Speaker
LAN	1 x RJ45, Optional PoE(PD, 802.3AT)		
Accessory			
Accessory	Quick Start Guide(Hardcopy) AC Adapter 12V/50W Power Cord 3 Pin Terminal Block to DC Jack		
Power			
Power Rating	12V DC in(Phoenix type)	POE	Power Device (PD), follows IEEE 802.3at (25 W)

Control

Button	1 x Power Button 1 x Reset Button
--------	--------------------------------------

DIMENSIONS UNIT:MM

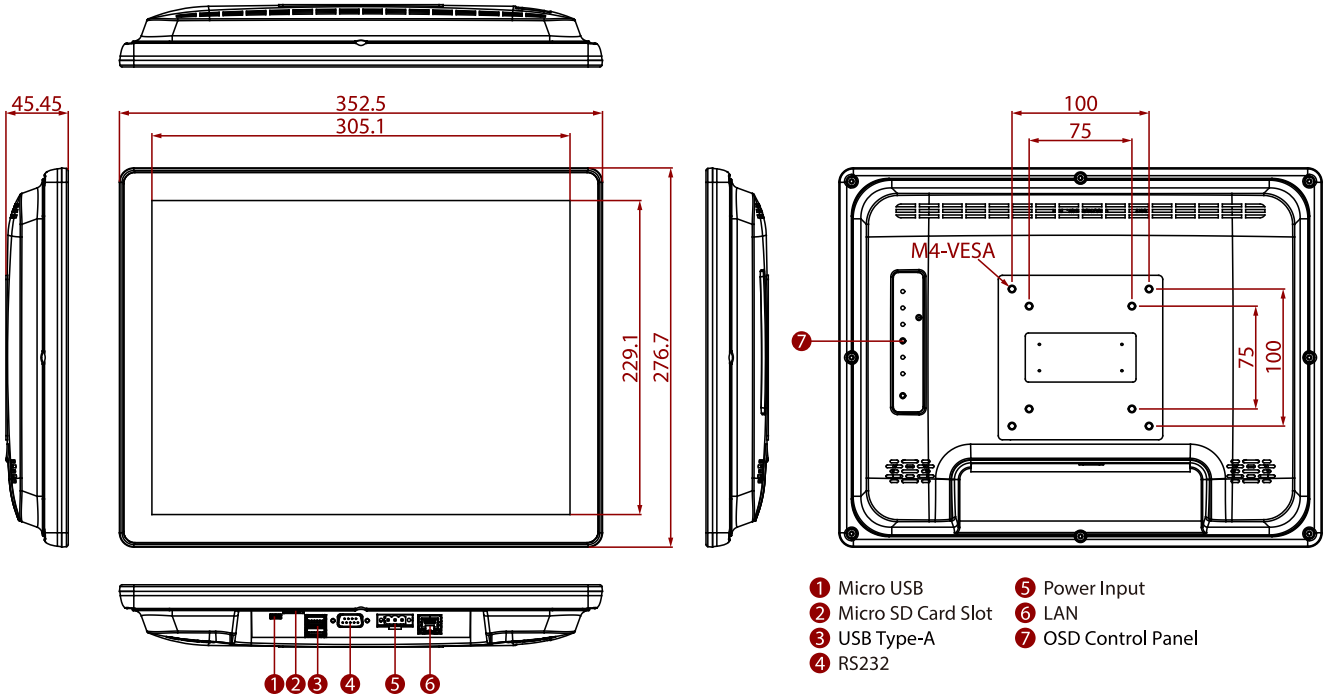

NOTE

1. This is a simplified drawing and some components are not marked in detail.
2. Please contact our sales representative if you need further product information.
3. All specifications are subject to change without prior notice.
4. The product shown in this datasheet is a standard model. For diagrams that contain customized or optional I/O, please contact the Winmate Sales Team for more information.