

# R19L100-67FTP(HB)

## 19" G-WIN IP67 Series Display



### KEY FEATURES

- Totally sealed Full IP67 aluminum compact housing design
- 19-inch 1280 x 1024 panel with Projected Capacitive touch screen
- -10 to 55°C wide operating temperature
- Fanless, streamlined enclosure for highly efficient heat dissipation
- Rugged Front Anti-Impact Design
- Front control membrane keys lockable by software
- Full IP67 male connectors with external female cables



### SPECIFICATIONS

Display	
<b>Resolution</b>	1280x1024
<b>Contrast Ratio</b>	1000:1
<b>Display Color</b>	16.7M Colors
<b>Active Area</b>	376.32x301.06 mm
<b>Optional function</b>	High brightness Panel for sunlight readable (Optional)
<b>Size</b>	19.0 inches
<b>Panel Brightness</b>	400 nits 1000 nits(Optional)
<b>View Angles</b>	85,85,80,80
<b>Touch / Glass</b>	Projected Capacitive Multi Touch Screen Bonding With Panel
Mechanical	
<b>Dimension</b>	474 x 410 x 111 mm
<b>Mounting</b>	Panel mount VESA Mount
<b>Cooling System</b>	Fanless design
<b>Weight</b>	9.8 kg
<b>Enclosure</b>	Aluminum Housing
<b>Cut out</b>	462 x 386mm
Environment	
<b>Operating Humidity</b>	10% to 90% RH, Non-Condensing
<b>Storage Temperature</b>	-30°C to 70°C
<b>Vibration</b>	MIL-STD-810G Method 514.6 Procedure I
<b>Operating Temperature</b>	-10°C to 55°C -40°C to 70°C (with intelligent heater)
<b>Shock</b>	MIL-STD-810G Method 516.6 Procedure I (Optional)
<b>IP rating</b>	IP67
Certification	
<b>Certification</b>	CE, FCC
IO Ports	
<b>Power Input</b>	1 x M12 waterproof connector for 9~36V DC
<b>Serial Port</b>	1 x M12 type connector for Touchscreen via RS232 signal (Optional)
<b>Indicator</b>	1 x LED Indicator for power 1 x LED Indicator for status
<b>USB Port</b>	1x M12 type connector for Touchscreen via USB signal
<b>Video</b>	1x M12 type connector for VGA input 1x M21 type connector for HDMI input (Optional)
Control	
<b>Button</b>	1 x Power Button 1 x Adjust up button 1 x Adjust down button 1 x ESC (Auto) button

1 x OK (Menu) button

## Accessory

**Accessory** External open wire Power cable with waterproof connector  
External USB cable with waterproof connector  
External VGA cable with waterproof connector  
Waterproof caps  
Mounting clips  
VESA screws

**Optional Accessory** 100~240V AC to DC Adapter with power cord (Optional)  
External COM cable with waterproof connector (Optional)  
External HDMI cable with waterproof connector (Optional)

## System Specification

## DIMENSIONS UNIT:MM

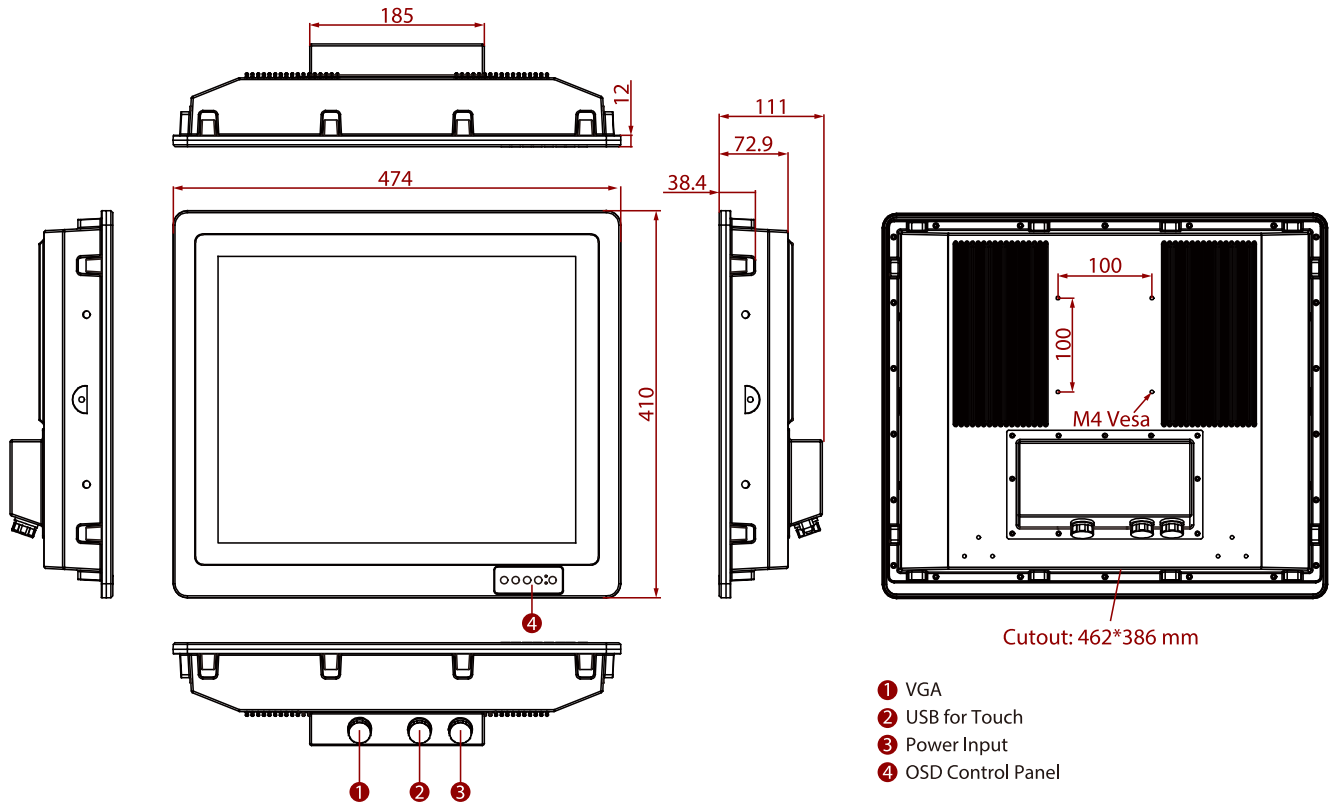

## NOTE

1. This is a simplified drawing and some components are not marked in detail.
2. The product shown in this datasheet is a standard model. For diagrams that contain customized or optional I/O, please contact the Winmate Sales Team for more information.
3. All specifications are subject to change without prior notice.