

R19L100-SPM169-P1

19" IP69K Stainless P-Series Display



KEY FEATURES

- 19" Projected capacitive multi-touch screen
- Fanless cooling system
- SUS 316 / AISI 316 stainless steel for food and chemical industries
- Full IP69K waterproof enclosure
- A true flat, easy-to-clean front surface with edge-to-edge design
- Waterproof sealed conduit pipe for cable protection
- Supports VESA mount and Yoke mount stand
- Optical bonding (optional)



SPECIFICATIONS

Display			
Resolution	1280x1024	Size	19 inches
Contrast Ratio	1000:1	Panel Brightness	250 nits
Display Color	16.7M Colors	View Angles	85,85,80,80
Active Area	376.32x301.06 mm	Touch / Glass	Projected Capacitive Multi Touch Screen
Mechanical			
Dimension	468 x 395 x 57 mm	Mounting	VESA Mount Yoke Mount
Enclosure	Stainless Housing	Cooling System	Fanless design
Environment			
Operating Humidity	10% to 90% RH, Non-Condensing	Operating Temperature	0°C to 45°C
Storage Temperature	-20°C to 60°C	IP rating	IP69K
Certification			
Certification	CE, FCC		
IO Ports			
USB Port	1x USB type-A for touch screen control	Video	1x VGA 1x HDMI (Optional)
Indicator	1 x LED Indicator for power 1 x LED Indicator for status		
Control			
Button	1 x Power Button 1 x Adjust up button 1 x Adjust down button 1 x ESC (Auto) button 1 x OK (Menu) button		
Accessory			
Accessory	1 x Waterproof Conduit 1.5m 1 x Waterproof Conduit 0.3m 2 x Elbow for connect the conduit 1 x AC to DC power adapter with power cord 1 x External USB cable for touchscreen control 1 x External HDMI cable 1 x D-sub15(male) to RJ45 adapter	Optional Accessory	1 x Open wire cable for phoenix connector (Optional) Yoke mount stand kit (Optional)

1 x D-sub15(female) to RJ45 adapter
 1 x External RJ45 male to male cable
 Manual
 VESA screws

Power

Power Rating 12V DC

DIMENSIONS UNIT:MM

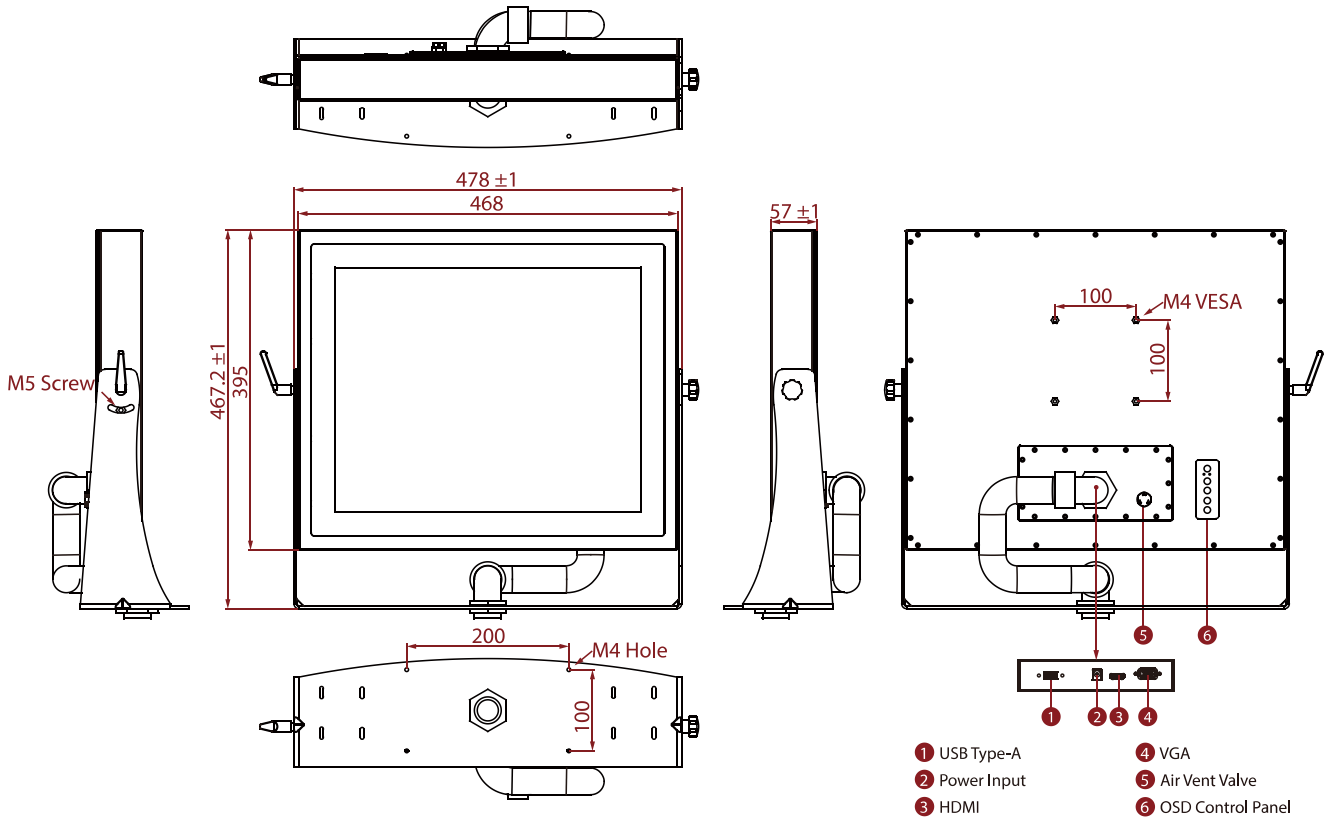

NOTE

1. This is a simplified drawing and some components are not marked in detail.
2. Please contact our sales representative if you need further product information.
3. All specifications are subject to change without prior notice.
4. The product shown in this datasheet is a standard model. For diagrams that contain customized or optional I/O, please contact the Winmate Sales Team for more information.