

# W12L100-PPB1

## 12.3" Multi-Touch Panel Mount Display



### KEY FEATURES

- 12.3" 1920 x 720 Resolution
- VGA input and HDMI input
- Panel mount
- Projected Capacitive Multi-Touch
- Front IP65



### SPECIFICATIONS

Display			
<b>Resolution</b>	1920x720	<b>Size</b>	12.3 inches
<b>Contrast Ratio</b>	1000:1	<b>Panel Brightness</b>	1000.0 nits
<b>Display Color</b>	16.7M Colors	<b>View Angles</b>	88,88,88,88
<b>Type</b>	Projected Capacitive Multi Touch		
Environment			
<b>Operating Humidity</b>	10% to 90% RH, Non-Condensing	<b>Operating Temperature</b>	0°C to 50°C
<b>Storage Temperature</b>	-10°C to 60°C	<b>IP rating</b>	Front IP65
Certification			
<b>Certification</b>	CE, FCC		
IO Ports			
<b>USB Port</b>	1 x USB for Touch Screen	<b>Video</b>	1 x VGA 1 x HDMI (Optional) 1 x DVI (Optional)
<b>Audio</b>	Audio line in (3.5mm) (Optional) 2 x Speaker (Optional)		
Mechanical			
<b>Dimension</b>	338.3 x 159.8 x 48.5 mm	<b>Weight</b>	5.5 kg
<b>Mounting</b>	Panel Mount	<b>Enclosure</b>	Metal Housing with Aluminum Bezel
<b>Cooling System</b>	Fanless Design	<b>Cut out</b>	318 x 140 mm
Accessory			
<b>Accessory</b>	1 x VGA cable 1 x HDMI cable 100~240V AC to DC Adapter Power Cord Manual VESA screws(Varies by product)	<b>Optional Accessory</b>	Remote Controller (Optional,Varies by product)
Power			
<b>Power Rating</b>	12V DC in		
Control			
<b>Button</b>	5 Keys: -, +, Power, Esc, Enter		

## DIMENSIONS UNIT:MM

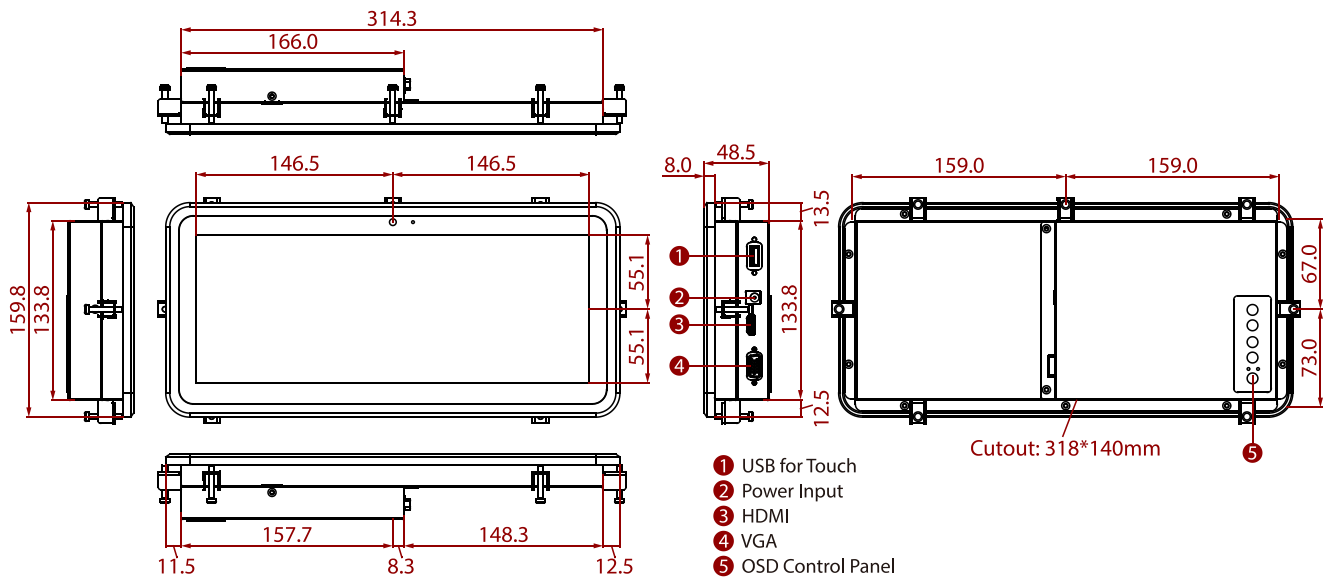

## NOTE

- 1.This is a simplified drawing and some components are not marked in detail.
- 2.Please contact our sales representative if you need further product information.
- 3.All specifications are subject to change without prior notice.
- 4.The product shown in this datasheet is a standard model.For diagrams that contain customized or optional I/ O, please contact the Winmate Sales Team for more information.