

W15IB3S-PTA3

15.6" Intel® Celeron® N2930 touch panel computers



KEY FEATURES

- 15.6" 1920 x 1080 with PCAP touch panel computers
- Intel® Celeron® N2930 1.83 GHz
- Fanless cooling system and ultra low power consumption
- Front IP65 for protection against water and dust
- Plastic housing
- A true flat, easy-to-clean front surface with edge-to-edge design



SPECIFICATIONS

Display			
Touch / Glass	Projected Capacitive Multi Touch Screen	Resolution	1920x1080
Size	15.6 inches	Contrast Ratio	800:1
Panel Brightness	400 nits	View Angles	85,85,85,85
Active Area	344.16x193.59 mm		
System Specification			
Processor	Intel Celeron N2930 1.83GHz (up to 2.16GHz)	Memory	1 x SO-DIMM, DDR3L 1600 MHz, 4GB 8GB (Optional)
Storage	1 x M.2 2242 B-key SSD 128GB. M.2 2242 B-key SSD up to 512GB. (Optional)	Ethernet controller	2 x Intel® Ethernet Controller
Operating System	Windows 10 IoT Enterprise (64 bit) (Optional) Linux Ubuntu 20.04 (Optional)		
Environment			
Operating Humidity	10% to 90% RH, Non-Condensing	Operating Temperature	0°C to 50°C
Storage Temperature	-10°C to 60°C	IP rating	Front IP65
Certification			
Certification	CE, FCC		
Mechanical			
Dimension	388 x 233 x 40 mm	Mounting	VESA Mount
Enclosure	Plastic	Cooling System	Fanless Design
IO Ports			
USB Port	1 x USB 3.0 1 x USB 2.0	Serial Port	1 x RS232(Default)/422/485
Audio	2 x Speaker	LAN	2 x RJ45-10/100/1000 Mbps
Indicator	Power LED Indicator		
Accessory			
Accessory	Quick Start Guide(Hardcopy) AC Adapter 12V/50W Power Cord		
Power			

Power Rating	12V DC in
Control	

Button	1 x Power Button 1 x Reset Button
---------------	--------------------------------------

DIMENSIONS UNIT:MM

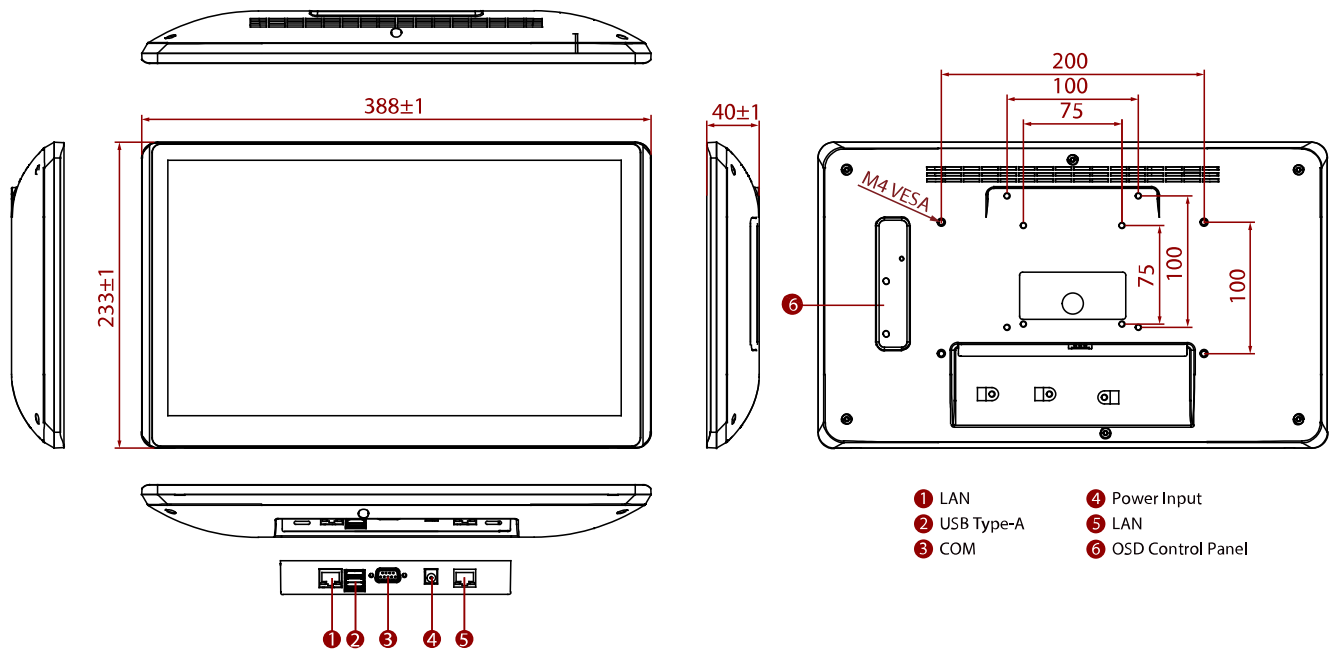

NOTE

1. This is a simplified drawing and some components are not marked in detail.
2. Please contact our sales representative if you need further product information.
3. All specifications are subject to change without prior notice.
4. The product shown in this datasheet is a standard model. For diagrams that contain customized or optional I/O, please contact the Winmate Sales Team for more information.