

# W10IB3S-GSH2

## 10.1" Intel® Celeron® N2930 G-WIN GS-Series Full IP65 PCAP Panel PC



### KEY FEATURES

- 10.1" 1280 x 800 Resolution with Projected Capacitive Multi-Touch (P-CAP)
- Intel® Celeron® Bay Trail-M N2930 1.83 GHz
- Fanless cooling system and ultra-low power consumption
- Edge-to-edge design
- Full IP65 design with Special M12 Waterproof connectors
- 1 x LAN, 1 x RS232, 1 x USB 2.0



### SPECIFICATIONS

Display			
<b>Resolution</b>	1280x800	<b>Size</b>	10.1 inches
<b>Contrast Ratio</b>	800:1	<b>Panel Brightness</b>	350 nits 1000 nits(Optional)
<b>View Angles</b>	85,85,85,85	<b>Active Area</b>	216.96 x135.6 mm
<b>Touch / Glass</b>	Projected Capacitive Multi Touch Screen Protection Glass (Optional)		
System Specification			
<b>Processor</b>	Intel® Celeron® N2930 (2M Cache, up to 2.16 GHz)	<b>Memory</b>	1 x SO-DIMM, DDR3L 1600 MHz, 4GB 8GB (Optional)
<b>Storage</b>	1 x mSATA SSD 64GB. mSATA SSD up to 512GB. (Optional)	<b>Ethernet controller</b>	2 x Intel® Gigabit Ethernet Controller
<b>Operating System</b>	Windows 10 IoT Enterprise (Optional) Linux Ubuntu 18.04 (Optional)	<b>WLAN</b>	Support (Optional)
<b>BT</b>	Support (Optional)		
Environment			
<b>Operating Humidity</b>	10% to 95% RH	<b>Operating Temperature</b>	-15 °C to 55 °C
<b>Storage Temperature</b>	-30°C to 60°C	<b>Shock</b>	40g for 11ms
<b>Vibration</b>	1.48/1.90/2.24 g rms for XYZ/ 5-500Hz	<b>IP rating</b>	Full IP65
Certification			
<b>Certification</b>	Compliant with MIL-STD-810F/G for vibration / shock, CE, FCC		
IO Ports			
<b>USB Port</b>	1 x USB 2.0 (M12 type)	<b>Serial Port</b>	1 x RS232 (M12 type)(Optional 422/485)
<b>LAN</b>	1 x LAN-10/100/1000 (M12 type)	<b>Indicator</b>	LED Indicators: Power, Storage
Power			
<b>Power Rating</b>	9-36V DC (M12 type)		
Accessory			
<b>Accessory</b>	Quick Start Guide (Hardcopy) Driver CD & User Manual M12 Power Cable		

M12 Serial Interface Cable  
M12 USB/ LAN Cable  
I/O Protective Cap x 3

**Control**

**Button** 1 x Power Button  
1 x Reset Button

**DIMENSIONS** UNIT:MM

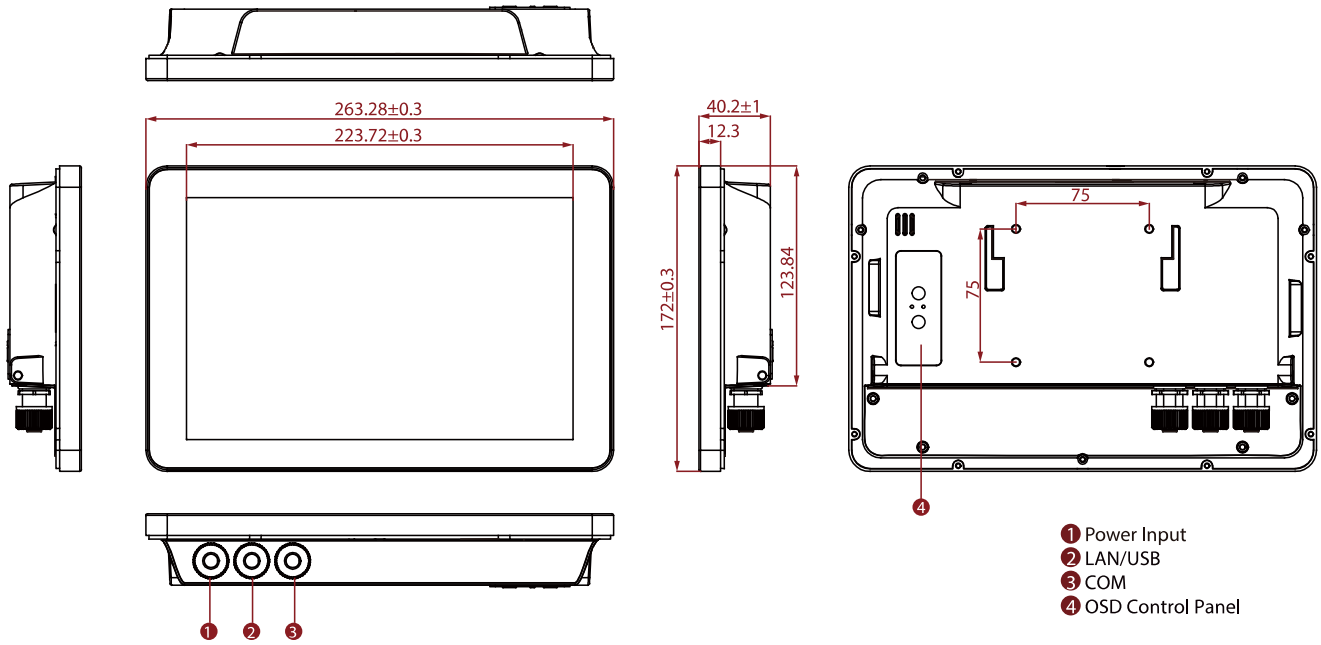

**NOTE**

1. This is a simplified drawing and some components are not marked in detail.
2. Please contact our sales representative if you need further product information.
3. All specifications are subject to change without prior notice.
4. The product shown in this datasheet is a standard model. For diagrams that contain customized or optional I/O, please contact the Winmate Sales Team for more information.