

R15L100-VMC3(HB)

15" G-WIN VM Series Display



KEY FEATURES

- High Quality 15" XGA panel, 1024 x 768 resolution
- 5 Wire resistive touch screen
- -10 ~ +55°C Wide Range Operating Temperature
- Anti-Corrosion housing with Fanless Design
- Built-in ambient Light sensor
- Front IP65 Dust & Waterproof Protection (Except I/O ports)
- 10 ~ 60V DC Isolation Wide Range Power Input. Optional Ignition on/off control function.



SPECIFICATIONS

Display			
Touch / Glass	Resistive Touch Screen (Optional) Protection Glass Without Touch Function (Optional)	Optional function	High brightness Panel for sunlight readable (Optional)
Resolution	1024x768	Size	15.0 inches
Contrast Ratio	2000:1	Panel Brightness	300 nits 1000 nits(Optional)
Display Color	16.2M Colors	View Angles	88,88,88,88
Active Area	304.1x228.1 mm		
Mechanical			
Dimension	398 x 308 x 58 mm	Weight	4.2 kg
Mounting	VESA Mount Yoke Mount	Enclosure	Aluminum Housing
Cooling System	Fanless design		
Environment			
Operating Humidity	10% to 90% RH, Non-Condensing	Operating Temperature	-10°C to 55°C
Storage Temperature	-30°C to 70°C	Shock	MIL-STD-810G Method 516.6 Procedure I (Optional)
Vibration	MIL-STD-810G Method 514.6 Procedure I	IP rating	Front IP65
Certification			
Certification	CE, FCC		
IO Ports			
Power Input	1 x 10~60V DC, 3-Pin Terminal Block	USB Port	1x USB type-A for touch screen control (Optional)
Serial Port	1 x RS232 D-sub9 for touch screen control (Optional)	Video	1x VGA input 1x HDMI input (Optional)
Indicator	1 x LED Indicator for power 1 x LED Indicator for status		
Control			
Button	1 x Power Button 1 x Adjust up button 1 x Adjust down button 1 x ESC (Auto) button 1 x Menu button		

Accessory

Accessory Open Wire Cable with terminal block connector
External VGA cable
VESA screws

Optional Accessory Yoke mount stand (Optional)
100~240V AC to DC Adapter with power cord (Optional)
External USB/COM cable for touchscreen control (Optional)
External HDMI cable (Optional)

System Specification

DIMENSIONS UNIT:MM

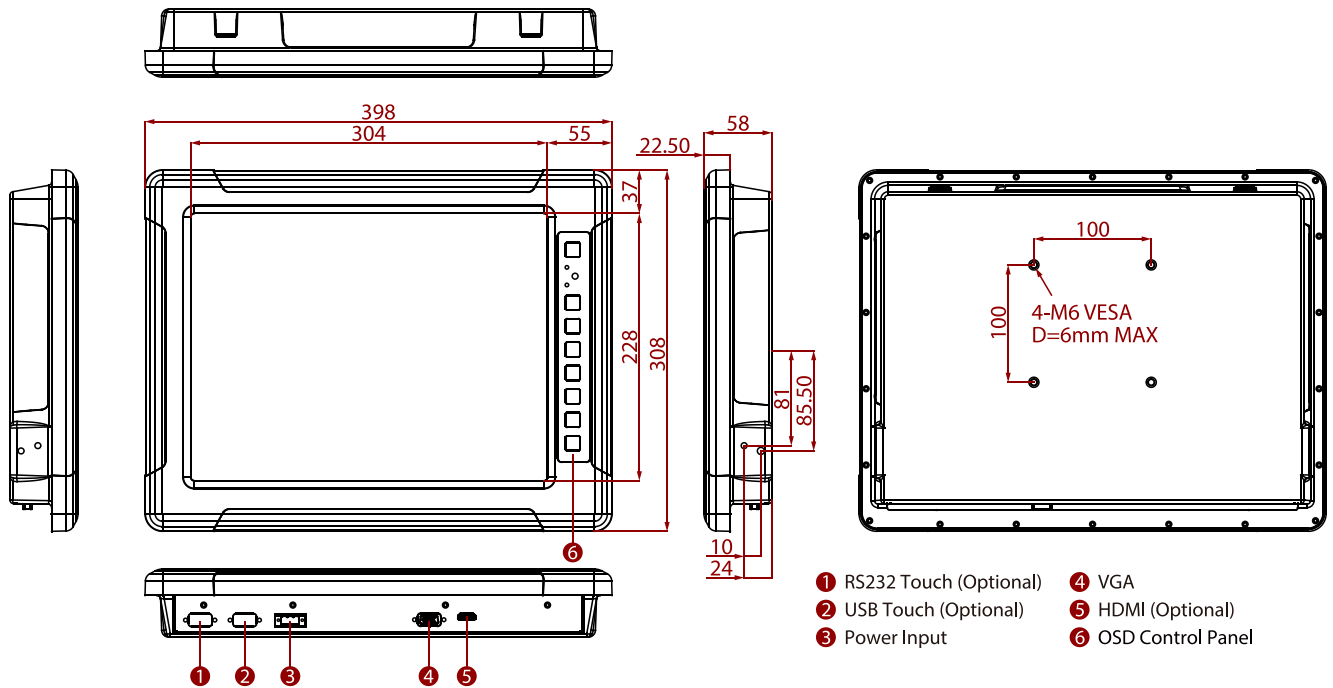

NOTE

1. This is a simplified drawing and some components are not marked in detail.
2. The product shown in this datasheet is a standard model. For diagrams that contain customized or optional I/O, please contact the Winmate Sales Team for more information.
3. All specifications are subject to change without prior notice.