

W15IM3S-PPB2

14.9" ARM A53 PP Series HMI Panel PC



KEY FEATURES

- 14.9" 1920 x 720 panel with projected capacitive multitouch screen
- ARM A53 Quad Core 2.0GHz CPU
- Front IP65 water and dust proof
- Aluminum housing and fanless design
- Room booking schedule, access control, room information display
- Support Android or Linux operating system



SPECIFICATIONS

Display			
Type	Projected Capacitive Multi Touch	Resolution	1920x720
Size	14.9 inches	Contrast Ratio	1000:1
Panel Brightness	950.0 nits	View Angles	85,85,85,85
Active Area	355.68x133.38 mm		
System Specification			
Processor	ARM A53 (Quad Core 2.0GHz)	Memory	4GB LPDDR4
Storage	eMMC: Onboard 32 GB	Operating System	Android 11 (Upgradeable to Android 13) Linux Yocto 5.10.104 with QT 5.15 (Optional) Linux Ubuntu (Optional)
WLAN	Support (Optional)	BT	Support (Optional)
Mechanical			
Dimension	400.2 x 187.6 x 59 mm	Mounting	Panel Mount VESA Mount
Enclosure	Metal Housing	Cooling System	Fanless Design
Cut out	378.1x164.6mm		
IO Ports			
USB Port	2 x USB 2.0 Type A 1 x Micro USB 2.0 OTG	Serial Port	1 x RS232/422/485 (Default RS232)
SD Card Slot	1 x Micro SD card slot (Max to 32GB)	Video	1 x Micro HDMI Output (Optional)
Audio	2 x Speaker (Optional)	LAN	1 x LAN 10/100/1000 Mbps
Environment			
Operating Humidity	10% to 90% RH, Non-Condensing	Operating Temperature	0°C to 50°C
Storage Temperature	-20°C to 60°C	Shock	MIL-STD-810G Method 516.6 Procedure I
Vibration	MIL-STD-810G Method 514.6 Procedure I	IP rating	Front IP65
Certification			
Certification	CE, FCC		
Control			
Button	1 x Power Button (Optional)		

Power			
Power Rating	12V DC with Terminal Block	Adapter	12V 50W
Accessory			
Accessory	100~240V AC to DC Adapter Power Cord VESA screws Manual Mounting clips		

DIMENSIONS UNIT:MM

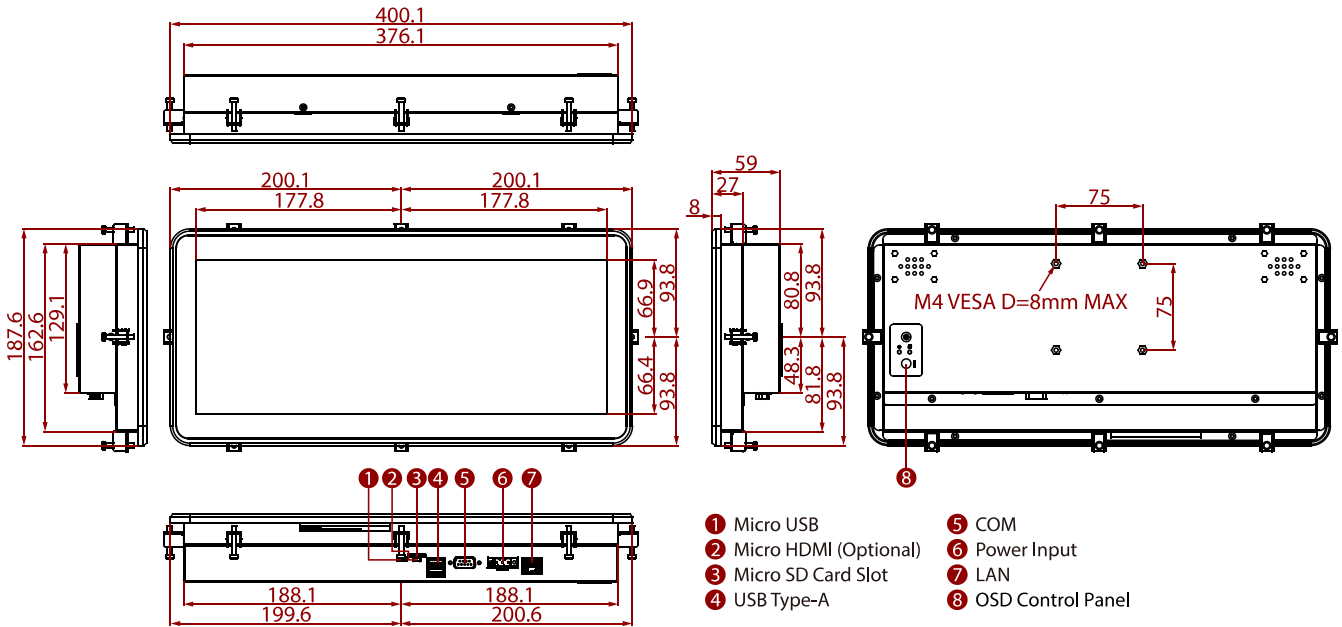

NOTE

- 1.This is a simplified drawing and some components are not marked in detail.
- 2.Please contact our sales representative if you need further product information.
- 3.All specifications are subject to change without prior notice.
- 4.The product shown in this datasheet is a standard model.For diagrams that contain customized or optional I/ O, please contact the Winmate Sales Team for more information.