

L140AD-4L

14-inch Rugged Laptop with Intel® Core™ i5-1235U



KEY FEATURES

- 12th Gen. Intel® Processor Family – Alder Lake Processor
- 14" 1920 x 1080 FHD LED panel
- Dual battery with hotswappable design for wholeday work
- Magnesium alloy enclosure with double injection for drop protection

INTRODUCTION

The Winmate L140 Series Rugged Laptop delivers exceptional performance, durability, and versatility for demanding environments. Powered by the Intel® Alder Lake processors, it features a sunlight-readable FHD display with direct optical bonding and anti-glare technology. Designed with a magnesium alloy enclosure and dual hot-swappable batteries, it ensures all-day reliability. The flip design offers quick switching between laptop and tablet modes, making it ideal for field operations, industrial tasks, and mission-critical applications.

OVERVIEW



Durability for Harsh Environment

Durable Build: Winmate Rugged Laptop is designed with a robust and durable exterior, compliant with US Defence Standard (MIL-STD-810H) for guaranteed performance. Winmate Rugged Laptop also certified with an IP65 rating, ensuring water and dust resistant.

Outdoor-Compatible: Winmate Rugged Laptop is built to thrive in challenging conditions, enduring extreme temperatures, repeated drops, humidity, ext. This rugged laptop is well-suited for industrial and defense applications, ensuring reliable performance in harsh environments.

Advanced Network Performance

Efficient Connectivity: Minimize downtime with the Winmate Rugged Laptop, equipped with WLAN, BT, and optional 4G/5G LTE for enhanced connectivity. Enjoy faster data transmission, ensuring reliable connectivity even in remote environments.



Optimal Computing Performance

Versatile Storage: Winmate Rugged Laptop is equipped with dual M.2 NVME solid-state drives (SSD), offering a combined storage capacity of up to 4 TB.

Reliable for 24/7 Operations: Winmate Rugged Laptop is designed with dual hot-swappable batteries, ensuring uninterrupted power for continuous operations.

SPECIFICATIONS

Display

Resolution	1920x1080	Size	14.0 inches
Contrast Ratio	800:1	Panel Brightness	300.0 nits
View Angles	85,85,85,85		

System Specification

Processor	Intel Core i5-1235U (up to 4.4GHz)	Memory	8GB DDR5 SDRAM 16GB DDR5 SDRAM (Optional) 32GB DDR5 SDRAM (Optional)
Storage	256GB M.2 NVMe SSD 512GB M.2 NVMe SSD (Optional) 1TB M.2 NVMe SSD (Optional) 2TB M.2 NVMe SSD (Optional) 2nd storage available with up to 2TB M.2 NVMe SSD (Optional)	Security	Trusted Platform Module (TPM) 2.0 Kensington Lock
Operating System	Windows 11 IoT Enterprise LTSC (64 bit) Windows 10 IoT Enterprise LTSC (64 bit) (Optional)	WLAN	Support
BT	Support	WWAN	4G LTE (Optional) 5G (Optional)
Smart Card Reader	Smart Card Reader (Mutually exclusive with 2nd LAN) (Optional)		

Camera

Front Camera	2MP Front Camera
---------------------	------------------

Mechanical

Dimension	340 x 230 x 38 mm	Weight	2.35 kg
Cooling System	Fan Design		

IO Ports

USB Port	1 x USB 3.0 (Type C) 3 x USB 3.0 (Type A) (One USB-A is mutually exclusive with 2nd LAN)	SD Card Slot	1 x Micro SDXC Slot
SIM Card Slot	1 x Nano SIM card slot	Video	1 x HDMI 4K Output (Optional)
Audio	1 x Audio combo 3.5mm audio combo jack Dual Digital Mic With Noise Cancellation Dual Speaker	LAN	1 x RJ45-10/100/1000 GigaLAN port Optional 2nd LAN (Mutually exclusive with one USB-A & Smart Card Reader)
Indicator	2x LED Indicator for Power, Battery		

Environment

Operating Humidity	10% to 90% RH, non-condensing	Operating Temperature	-10°C to 50°C
Storage Temperature	-30°C to 70°C	Shock	MIL-STD-810H Method 516.8 Procedure I
Vibration	MIL-STD-810H Method 514.8 Procedure I	IP rating	IP65
Drop	MIL-STD-810H Method 516.8, 3 ft		

Certification

Certification	CE, FCC
----------------------	---------

Security Function

SOTI MobiControl	SOTI MobiControl Compliance	Kensington Lock	Kensington Lock Support
-------------------------	-----------------------------	------------------------	-------------------------

Control

Button	QWERTY keyboard with backlight
---------------	--------------------------------

Power

Battery	Hot-swappable 2 x 11.55V, typ. 3220 mAh Li-Ion Battery (3S1P)	Battery Operating Time	Standard Battery: 11 hours
Power Rating	19V DC	Adapter	100-240V, 50-60Hz / 19V DC

DIMENSIONS UNIT:MM

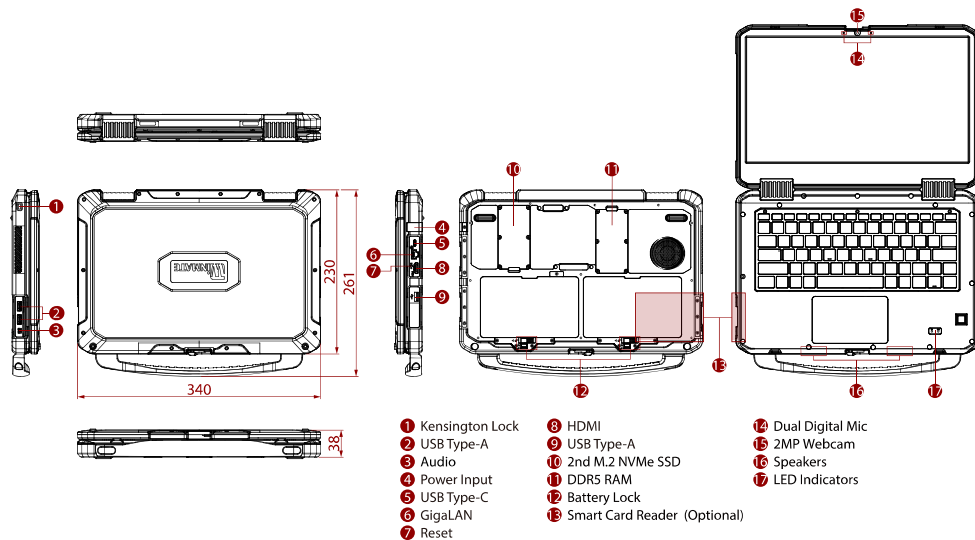

NOTE

/ Disclaimer /

- Accessories and Integrated Options may vary depending on your configuration.
- Total usable memory and storage will be less dependent upon actual system configuration.
- The actual transfer speed will vary depending on many factors including the processing speed of the host device, file attributes, and other factors related to the system configuration and your operating environment.
- The USB Type-C connector follows USB 3.0 standard, which does not support Alternate Mode (ALT) or USB Power Delivery (USB-PD).
- The battery life is measured at dimming LCD brightness. Varies depending on the usage conditions, or when an external device is attached.
- The 2D drawing is simplified drawing and some components are not marked in detail.
- Length measurements do not include protrusions. Weight varies with options.
- TPM 2.0 available upon request.
- SOTI is available upon request.
- The product shown in this datasheet is a standard model. For diagrams that contain customized or optional I/O, please contact the Winmate Sales Team for more information.