

# G101AD-A

10.1" Intel® Core™ i5-1235U Rugged Robotic Controller



## KEY FEATURES

- 10.1" 1920 x 1200 IPS LED Panel with direct optical bonding
- Intel® Core™ i5-1235U processor
- All-weather, dust, and water-resistant design (IP65). MIL-grade drop, Shock and vibration
- Supports WIFI, BT and optional 4G/5G
- With one removable battery

## INTRODUCTION

Winmate's Rugged Handheld Robotic Controller Series is a versatile and durable solution tailored for robotics, defense, public safety, and industrial automation. Available in sizes from 5.5" to 10.1", these controllers support Windows, Android, and Linux, providing flexibility for various applications. Featuring IP65-rated water and dust resistance, along with MIL-grade shock and vibration protection, they are built for all-weather reliability. With PCAP touchscreens, Intel or ARM processors, Wi-Fi, Bluetooth, and optional 4G connectivity, these robotic controllers deliver robust performance in demanding environments.

## OVERVIEW



### Rugged and Advanced Build Design

The Winmate G101AD-A Handheld Robotic Controller is built for durability and high performance in demanding environments. Featuring an Intel® processor, it provides the computing power required for a wide range of applications, including robotic operations. Its rugged design meets IP65 standards for water and dust resistance and adheres to military-grade certifications for drop, shock, and vibration resistance, ensuring dependable functionality even in the harshest industrial conditions.

### Uninterrupted Operation with Hot-Swappable Power

Equipped with a removable battery, the G101AD-A ensures uninterrupted operations, even during extended use. The hot-swappable design allows users to replace the battery without powering down the device, making it ideal for critical applications that demand consistent uptime. This feature minimizes downtime and enhances productivity, particularly in field operations.





### Seamless Connectivity Across Network

Designed for seamless communication, the G101AD-A supports WiFi, Bluetooth, and optional 4G/5G connectivity. These connectivity options provide reliable and high-speed data transfer, ensuring smooth integration with robotic systems and other industrial networks. This enhanced connectivity empowers users with real-time control and data access in diverse applications, from smart manufacturing to defense applications.

## SPECIFICATIONS

### Display

<b>Resolution</b>	1920x1200	<b>Size</b>	10.1 inches
<b>Contrast Ratio</b>	800:1	<b>Panel Brightness</b>	800.0 nits
<b>View Angles</b>	85,85,85,85	<b>Bonding</b>	Optical Bonding for Sunlight Viewability
<b>Type</b>	Projected Capacitive Multi Touch	<b>Viewability</b>	AG+AF touch treatment

### System Specification

<b>Processor</b>	Intel® Core™ i5-1235U 3.3GHz(up to 4.40 GHz) Intel Core i3/i7 Processor (Optional)	<b>Memory</b>	8GB DDR5 SDRAM, up to 32GB
<b>Storage</b>	256GB SSD 512GB SSD (Optional) 1TB SSD (Optional) 2TB SSD (Optional)	<b>Operating System</b>	Windows 10 IoT Enterprise LTSC (64 bit) (Optional) Windows 11 IoT Enterprise LTSC (64 bit) (Optional) Linux Ubuntu 22.04 (Optional)
<b>WLAN</b>	Support	<b>BT</b>	Support
<b>WWAN</b>	4G LTE (Optional) 5G (Optional)	<b>GNSS</b>	GPS/GLONASS

### Mechanical

<b>Dimension</b>	317.75 x 188.87 x 35.8 mm	<b>Cooling System</b>	Fan Design
------------------	---------------------------	-----------------------	------------

### IO Ports

<b>USB Port</b>	1 x USB 3.0 (Type-A) 1 x USB 3.2 Gen 2 x 1 (Type C)	<b>Video</b>	2 x micro HDMI output
<b>Audio</b>	2x Speaker	<b>LAN</b>	1 x M8 LAN Connector (10/100 Mbps , Max to 250 Mbps)

### Environment

<b>Operating Humidity</b>	10% to 90% RH, non-condensing	<b>Operating Temperature</b>	-20°C to 60°C (AC mode), -10°C to 50°C (Battery mode)
<b>Storage Temperature</b>	-30°C to 70°C (-22°F to 158°F)	<b>Shock</b>	MIL-STD-810H Method 516.8 Procedure I
<b>Vibration</b>	MIL-STD-810H Method 514.8 Procedure I	<b>IP rating</b>	IP65

### Certification

<b>Certification</b>	CE, FCC
----------------------	---------

### Control

<b>Button</b>	2 x Toggle Switch 2 x joystick 2 x Roller switch 6 x buttons
---------------	---

### Power

<b>Battery</b>	11.1V, typ. 6400 mAh LiIon Removable Battery (3S2P)	<b>Power Rating</b>	1 x USB (Type C) (Charging)
<b>Adapter</b>	PD Adapter 100W		

### Accessory

<b>Accessory</b>	1 x PD Adapter 100W 1 x M8 LAN external cable(2M) 1 x Power Cord	<b>Optional Accessory</b>	shoulder strap(Optional)
------------------	--	---------------------------	--------------------------

**DIMENSIONS** UNIT:MM

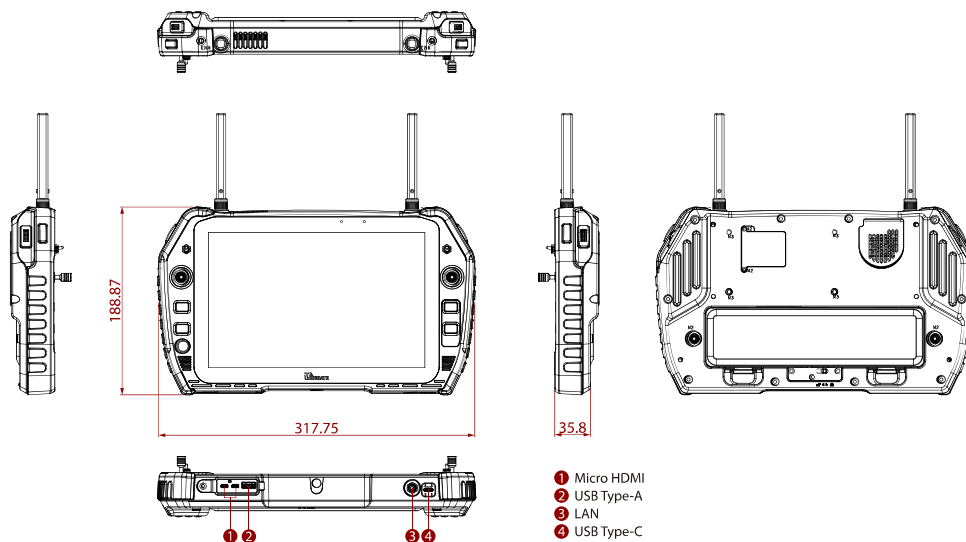

**NOTE**

- 1.This is a simplified drawing and some components are not marked in detail.
- 2.Please contact our sales representative if you need further product information.
- 3.All specifications are subject to change without prior notice.
- 4.The product shown in this datasheet is a standard model.For diagrams that contain customized or optional I / O, please contact the Winmate Sales Team for more information.